



SH300 HAND SWING & SH300 W/HANDWINCH HOIST INSTRUCTIONS

REIMANN & GEORGER CORPORATION
HOISTING PRODUCTS
P/N 6102060

BUFFALO, NY
7/21/09

PRE-HOISTING CHECKLIST

This checklist must be checked prior to each use of the hoist. This checklist is to be used as a guideline in conjunction with the maintenance and inspection procedures outlined in this manual. The hoist and related equipment must be thoroughly inspected prior to each use by a trained person. A trained person is one who has read and thoroughly understands this instruction manual and related equipment manuals and, through training and experience, has shown knowledge regarding the safe operational procedures. If you do not have such a person in your organization, please contact Reimann & Georger Corporation or its distributors and they will assist you in providing such a "trained person." Do not permit any person who is not fully trained to operate this hand swing hoist. It is recommended that this checklist be maintained as a permanent record.

- Discuss work plan, personal protective equipment, and each crew member's responsibility before starting to set-up.
- Ensure OSHA compliant fall protection is in place.
- Ensure a competent person has determined the structural deck can support the intended loads in hoisting and material handling.
- Ensure hoisting operation will clear all power lines and obstructions.
- Ensure hoisting area is secured from all unauthorized personnel.
- Ensure all shackles and safety hooks have a rated capacity of at least 300 lbs. and are in good condition.
- Ensure hoisting rope has a working load rating of at least 300 lbs. and is in good condition.
- Ensure boom gin pulley can rotate freely and has a load rating of at least 600 lbs.
- Ensure 600 lbs. of Reimann & Georger Corporation approved ballast blocks are secured in the ballast box with rope.
- Ensure slings are commercially manufactured and in good condition.
- The capacity of slings decreases as the angle increases. Ensure slings have a rated load capacity of at least 300 lbs.
- Ensure safety latch on the hook does not support any load.
- Inspect hoisting rope, or handwinch and wire rope, for signs of wear or damage. Replace if required.
- Ensure all structural members of the hoist are free of defects and damage that may affect its integrity.
- Ensure the pre-installed bolt and nut connecting the counterweight leg assembly and the front leg is in good condition.
- Ensure the front leg socket is properly connected with the counterweight leg assembly.
- Ensure the boom lock lever is fastened with the provided wing screw.
- Ensure the boom is secured with the pin spring in the top of the front leg.
- Ensure the stabilizer bar is installed on the side opposite to the boom unloading position on the roof deck.
- Ensure the tether line is tied on the boom D-ring.
- Ensure the front leg is vertically plumb.

INSPECTOR: _____ **DATE:** _____

TABLE OF CONTENTS

CHAPTER	TITLE	PAGE
1	SAFETY	1
1.1	Introduction	1
1.2	Safety Definitions	1
1.3	Hoist Safety Labels.....	1
1.4	Hoist Safety Rules	1
2	SPECIFICATIONS	3
2.1	Technical Data.....	3
2.2	Nameplate and Serial Number Tag.....	3
3	INSTALLATION AND SETUP	4
3.1	Pre-Installation Checks	4
3.2	Ballast Block Assembly.....	4
3.3	Assembling The Frame	5
3.4	Gin Pulley Assembly	6
3.5	Handwich Assembly	7
3.6	Reeving Wire Rope.....	7
3.7	Preparing Hoist For Use	8
4	OPERATION	9
4.1	Before Operating The Hoist.....	9
4.2	Raising And Lowering The Load	9
4.3	Hand Signals.....	11
4.4	Preparing Hoist For Shutdown	12
5	DISASSEMBLY	13
5.1	Removing the Hoisting Rope.....	13
5.2	Disassembling the Frame.....	13
6	INSPECTION AND MAINTENANCE	14
6.1	General Maintenance Rules	14
6.2	Initial Inspection	14
6.3	Daily Inspection.....	14
7	TROUBLESHOOTING	15
8	PARTS LIST	16
8.1	SH300	16
8.2	SH300 w/ Handwinch.....	18

LIST OF FIGURES

FIGURE	DESCRIPTION	PAGE
2-1	Typical Hoist Product Nameplate	3
3-1	Ballast Block Assembly	5
3-2	Ballast Block Filling.....	5
3-3	Wire Rope Installation to Winch.....	7
4-1	“Hoist” Signal	11
4-2	“Lower” Signal.....	11
4-3	“Stop” Signal.....	11
4-4	“Emergency Stop” Signal.....	12
4-5	“Move Slowly” Signal	12
8-1	SH300 Assembly—Front View.....	17
8-2	SH300 Assembly—Side View	17
8-3	SH300 with Handwinch- Front View.....	19
8-4	SH300 with Handwinch- Side View	20

1 SAFETY

1.1 INTRODUCTION

Your Reimann & Georger Corporation SH300 Hand Swing Hoist has been engineered to provide lifting performance, long term economics and safety advantages that no other type can match. However, even a well-designed and well-built hoist can malfunction or become hazardous in the hands of an inexperienced and/or untrained user. Therefore, read this manual and related equipment manuals thoroughly before operating your hoist to provide maximum safety for all operating personnel, and to get the maximum benefit from your equipment.

1.2 SAFETY DEFINITIONS

A safety message alerts you to potential hazards which could injure you or others or cause property damage. The safety messages or signal words for product safety signs are **DANGER**, **WARNING**, and **CAUTION**. Each safety message is preceded by a safety alert symbol and is defined as follows:

DANGER: Indicates an imminently hazardous situation which, if not avoided, **will** cause death or serious injury. This safety message is limited to the most extreme situations.

WARNING: Indicates potentially hazardous situation which, if not avoided, **could** result in death or serious injury.

CAUTION: Indicates a potentially hazardous situation which, if not avoided, **may** result in minor or moderate injury. It may also be used to alert against unsafe practices and property-damage-only accidents.

1.3 HOIST SAFETY LABELS

These labels warn you of potential hazards that could cause injury. Read them carefully. If a label comes off or becomes illegible, contact Reimann & Georger Corporation for a free replacement.

1.4 HOIST SAFETY RULES

1. Operators must be thoroughly trained before operating this hoist. A trained person is one who has read and thoroughly understands this instruction manual and, through training and experience, has shown knowledge regarding the safe operational procedures.
2. Prior to setting up the hoist there must be a plan of action outlining the work to be accomplished, individual responsibilities, personal protective equipment, and method of communication.
3. A good line of communication must be maintained between the hoist operator and the ground crew. All crew members must be familiar with hand signals. Hand signals are shown in Chapter 4.
4. Follow the Pre-Hoisting Checklist before operating.
5. Use only Reimann & Georger Corporation concrete filled ballast blocks or factory approved equal as counterweight.
6. Ensure 600 lbs. (272 kg.) of ballast blocks are secured properly in the ballast box before operating the hoist. Tie ballast blocks securely to the four (4) tie down rings. **No** human being shall **ever** be utilized as ballast.
7. Gin Pulley must have a capacity rating of 600 lbs.
8. Hoisting rope must have a working load rating of at least 300 lbs.
9. Wear heavy leather gloves when handling hoisting rope.
10. All personnel shall be protected by OSHA compliant fall protection.

11. Never use the hoist structure to anchor life lines, worker's harnesses or other attachments.
12. Hoisting area is to be clear of power lines. Consult power company before you work near power lines.
13. Hoisting area is to be kept clear of unauthorized personnel at all times. Place barricades or secure the area in such a manner that no personnel would be injured by the use of the equipment or by equipment failure.
14. Keep out from under a raised load.
15. Never hoist over an open doorway.
16. Never exceed the Rated Load Capacity of 300 lbs. The Rated Load Capacity is the maximum load which should ever be applied to the hoist. Rated Load Capacity is for straight line pull; avoid side loads.
17. All hoisting accessories such as slings must be commercially manufactured.
18. All pulleys, hooks, slings, shackles, and other hoisting accessories must be properly maintained and installed.
19. Secure load before lifting.
20. Tag lines shall be used to control loads when there is danger it may swing or drift out of control.
21. The boom lock lever must securely lock the boom in position when hoisting a load and lowering it onto the roof.
22. Never attach hoisting rope to any powered device.
23. When hoisting from the ground insure **all** personnel stand clear of the raised load.
24. When hoisting a load from the roof, ensure OSHA compliant fall protection is used and footing is on a firm surface.
25. Check the hoist periodically during operation.
26. At end of operation, the hoist should be secured to prevent unauthorized use. Never assume you will find the hoist in the same condition in which you left it.
27. Do not weld or otherwise modify the hoist. Such alterations may weaken the structural integrity of the hoist.
28. Only trained personnel are authorized to do repairs.
29. Do not operate hoist when under the influence of drugs, alcohol, or medication.

2 SPECIFICATIONS

2.1 TECHNICAL DATA

The following specifications apply to the hoist assembly.

Capacity	300 lbs.
Counterweight required	600 lbs.
Ballast blocks required	12
Ballast block weight (minimum)	50 lbs.
Frame weight	125 lbs.
Operator fence (optional)	12 lbs.
Boom height	7 ft.
Boom overhang	4 ft.
Handwinch	5/32 diameter x 60 ft.

2.2 NAMEPLATE AND SERIAL NUMBER TAG

It is important to identify your hoist completely and accurately whenever ordering spare parts or requesting assistance in service. The hoist has a product nameplate located on the boom. The label shows the model and serial numbers and capacity rating. The hoist label should appear as the sample nameplate shown in Figure 2-1. Record the model and serial numbers for future reference.

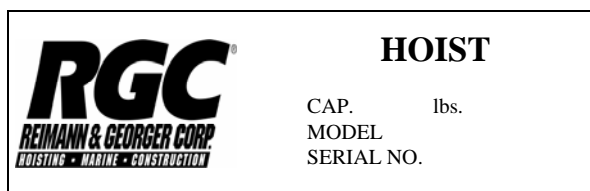

Figure 2-1.
Typical Hoist Product Nameplate

MODEL _____

SERIAL NUMBER _____

CAPACITY RATING **300 LBS.** _____

3 INSTALLATION AND SETUP

The reference numbers and letters used in the assembly drawings of Chapter 3 are the same as those listed in the parts lists of Chapter 8.

3.1 PRE-INSTALLATION CHECKS

1. Do not assemble the hoist if any part shows any sign of damage.



WARNING:

ENSURE ALL STRUCTURAL MEMBERS OF THE HOIST ARE FREE OF DEFECTS AND DAMAGE THAT MAY AFFECT THE INTEGRITY OF THE UNIT.

2. Do not weld or otherwise modify the hoist. Such alterations may weaken the structural integrity of the hoist and void the warranty.



WARNING:

A COMPETENT PERSON MUST DETERMINE THAT THE STRUCTURAL DECK CAN SUPPORT THE INTENDED LOADS IN HOISTING AND MATERIAL HANDLING IN ADDITION TO THE WEIGHT OF THE COUNTERWEIGHT ON THE ROOF DECK. FAILURE TO DO THIS CAN RESULT IN DEATH, SERIOUS PERSONAL INJURY OR EQUIPMENT FAILURE.

3. Hoist installation and setup cannot proceed until all necessary parts and equipment have been raised to the roof where the hoisting operation will be done.



WARNING:

ENSURE THE HOISTING AREA IS SECURED FROM ALL UNAUTHORIZED PERSONNEL. ENSURE THAT OSHA COMPLIANT FALL PROTECTION IS IN PLACE.



WARNING:

PRIOR TO SETTING UP THE HOIST THERE MUST BE A PLAN OF ACTION OUTLINING THE WORK TO BE ACCOMPLISHED, INDIVIDUAL RESPONSIBILITIES, PERSONAL PROTECTIVE EQUIPMENT, AND THE METHOD OF COMMUNICATION. FAILURE TO DO THIS CAN RESULT IN DEATH, SERIOUS PERSONAL INJURY OR EQUIPMENT FAILURE.

3.2 BALLAST BLOCK ASSEMBLY

Before using the Ballast Blocks, they must be filled with the proper amount of concrete. Prepare the Ballast Blocks as follows:

1. Place the Ballast Block handle in the base section of the ballast weight. (This is the section without the filling hole.) This handle can stand upright by itself. Position top section of Ballast Block over base section, push down and snap into position. See Figure 3-1.
2. Place a funnel into the opening and pour a loosely mixed, flowing concrete into the box. Funnel may require slitting to fit opening of Ballast Block. To achieve the required Ballast Block weight of 50 pounds, fill it completely by positioning it on an angle. See Figure 3-2.



WARNING:

TO ACHIEVE THE REQUIRED BALLAST BLOCK WEIGHT OF 50 POUNDS, BE SURE TO FILL BLOCK COMPLETELY. THE WEIGHT OF THE BALLAST BLOCK MAY VARY DUE TO THE CONSISTANCY OF THE CONCRETE MIX. DO NOT USE MOTOR MIX. THIS WILL NOT GIVE THE REQUIRED MINIMUM BALLAST BLOCK WEIGHT OF 50 POUNDS. USE A SCALE TO DETERMINE THE WEIGHT OF THE BALLAST. THIS WILL ENSURE SAFE OPERATION IN ACCORDANCE WITH THESE INSTRUCTIONS.

- 3. Allow the concrete to set 10 minutes; then remove excess concrete from handle area to allow hand clearance. Wipe off top and base of box to allow nesting into the Counterweight Basket.

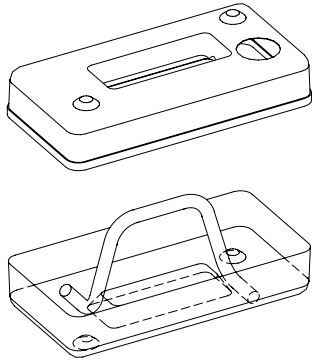

**Figure 3-1.
Ballast Block Assembly**

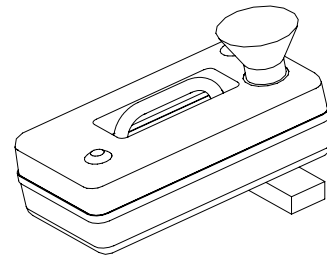

**Figure 3-2.
Ballast Block Filling**

3.3 ASSEMBLING THE FRAME

Refer to Figures 8-1 and 8-2 (SH300) or Figures 8-3 and 8-4 (SH300 w/ Handwinch) assembly drawings in Chapter 8 throughout this procedure.



WARNING:

NEVER ASSEMBLE THE FRAME NEAR A ROOF EDGE. ANY ACCIDENT NEAR A ROOF EDGE CAN CAUSE DEATH OR SERIOUS PERSONAL INJURY.

- 1. Stand the Front Leg Assembly (1) on the roof deck with the top leaning away from roof edge and Counterweight Leg Socket (6) facing away from the roof edge.
- 2. Attach the upper tube of Counterweight Leg Assembly (3) to the upper mounting bracket using pre-installed Hex Head Cap Screw (10) and Hex Nut (11). Do not tighten at this time.
- 3. Slowly lift front leg and slide lower counterweight leg tube into counterweight leg socket until front leg is in a plumb (vertical) position. Tighten the two Screwlocks (7) and upper mounting hardware.



WARNING:

ENSURE HEX HEAD CAP SCREW AND SCREWLOCK ARE PROPERLY CONNECTED AND IN GOOD CONDITION.

- 4. Remove Spring Pin (8) from top of front leg.
- 5. Install Boom Assembly (2), by lifting the upper boom mount over the top of front leg center tube and engage the lower boom mount against the same tube. Then lower the boom fully onto both bearings.

6. Attach Lock Lever (14) to the front leg mounting bracket, using the boom Screwlock. Tighten the screwlock, then back off 1/4 turn.
7. Reinstall spring pin in top of front leg to secure boom.
8. The Stabilizer Bar (5) can be installed on either side of front leg, but must be on the side **opposite** to where the boom will be swung to handle loads on the roof deck.



WARNING:

MOUNTING THE STABILIZER BAR ON THE WRONG SIDE WILL PREVENT THE BOOM FROM BEING FULLY SWUNG INTO THE PROPER POSITION ON THE ROOF DECK.

9. If the optional Operator Fence (18) will be used, install it on the side that the boom will be swung using the hardware included with it. Then tighten all hardware.
10. Swing the boom to the side opposite the stabilizer bar and lock in position with the boom lock lever. Attach the provided Manila Rope (15) to the D-ring on the boom for use as tether line.

3.4 GIN PULLEY ASSEMBLY

1. Install Gin Pulley (17) onto the end of the boom.



WARNING:

THE GIN PULLEY MUST HAVE A LOAD RATING OF AT LEAST 600 LBS.

2. Reeve hoisting rope through the gin pulley. Before applying any load, inspect the rope for wear and damage. Wear heavy leather gloves when handling rope.



WARNING:

THE HOISTING ROPE MUST HAVE A WORKING LOAD RATING OF AT LEAST 300 LBS.



WARNING:

WEAR HEAVY LEATHER GLOVES WHEN HANDLING HOISTING ROPE.



WARNING:

NEVER USE A ROPE FOR HOISTING THAT IS WORN OR DAMAGED. REPLACE IMMEDIATELY.

3. Attach a shackle and safety hook to the hoisting rope.



WARNING:

ENSURE SHACKLE AND HOOK HAVE A RATED CAPACITY OF AT LEAST 300 LBS. AND ARE IN GOOD CONDITION.

3.5 HANDWINCH ASSEMBLY

1. **Refer to Figure 8-3.** Install Pivot Bracket (23) onto the side of front leg assembly the stabilizer bar is mounted on using Hex Head Cap Screw (19 & 20) and two Hex Nuts (11).
2. Install the Diagonal Boom Brace (27) between the pivot sheave bracket and front leg using two each Hex Head Cap Screw (20) and Hex Nut (11).
3. Install Pivot Sheave Assembly (21) onto pivot bracket using the hole in the bracket closest to center of front leg.
4. **Refer to Figure 8-4.** Install Handwinch (24) onto counterweight leg (3) so the crank is located on the right-hand side using two each Hex Head Cap Screw (25) and Hex Nut (26).

3.6 REEVING THE WIRE ROPE

1. While wearing heavy leather gloves, inspect the wire rope for signs of any wear or damage. Discard wire rope immediately if found defective.



WARNING:
WEAR HEAVY LEATHER GLOVES WHEN HANDLING WIRE ROPE.



WARNING:
DISCARD DEFECTIVE WIRE ROPE IMMEDIATELY.

2. **Refer to Figure 8-3.** Starting from underside of the boom reeve the free end of the 5/32" diameter wire rope overtop of the boom sheave.



WARNING:
NEVER CLIMB THE HOIST FRAME TO REEVE THE WIRE ROPE. USE A STEP LADDER (NOT AN EXTENSION LADDER) WITH OSHA COMPLIANT FALL PROTECTION.

3. Reeve free end of wire rope through the front leg pivot sheave.
4. Guide the free end of wire rope overtop the winch drum and through the side hole of the drum nearest the wire rope clamp. Feed wire rope under clamp with 1" extending beyond clamp and tighten hex nuts securely.

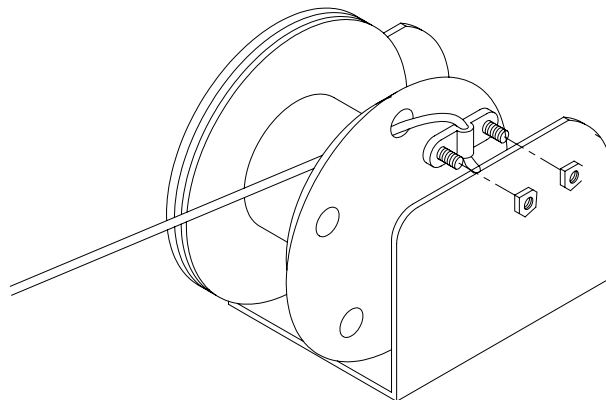

Figure 3-3.
Wire Rope Installation

5. While wearing heavy leather gloves turn the winch handle clockwise to begin winding wire rope onto winch drum. It is very important to keep tension on wire rope and maintain no gaps between each wrap around the drum.
6. When replacing or rewinding wire rope, ensure wire rope is feeding onto **top** side of the drum. The winch will operate with an audible ratcheting noise. If the wire rope feeds onto the bottom of the drum, the winch will not function properly.
7. Attach counterweight to safety hook to maintain tension on wire rope to prevent slack at drum.

3.7 PREPARING HOIST FOR USE

1. Position hoist assembly near roof edge of supporting wall. Ensure the front leg is mounted to a 2"x 6" board to distribute the load and the board is fastened to the supporting wall. Ensure 3/4" plywood is placed under counterweight basket to distribute the weight.
2. Mount 12 Ballast Blocks (16), (600lbs. total) as counterweight and tie securely to ballast box frame with rope. For equipment protection and safety of personnel, the counterweight Ballast Blocks must be prepared properly. Follow the detailed procedures given in section 3.2.



WARNING:

BEFORE RAISING A LOAD, ENSURE 600 LBS. OF REIMANN & GEORGER CORPORATION APPROVED BALLAST BLOCKS ARE SECURED PROPERLY IN THE COUNTERWEIGHT BASKET WITH ROPE BEFORE OPERATING THE HOIST. INADEQUATE COUNTERWEIGHT CAN CAUSE TOPPLING OF EQUIPMENT, RESULTING IN DEATH OR SERIOUS PERSONAL INJURY.



WARNING:

NEVER USE HUMAN BEINGS AS BALLAST AS THE EQUIPMENT IS NOT DESIGNED FOR THE SAME AND CAN RESULT IN DEATH OR SERIOUS INJURY.



WARNING:

PERSONNEL MUST NEVER SECURE A LIFE LINE TO THE HOIST FRAME STRUCTURE. IT IS NOT DESIGNED FOR THE SAME AND CAN RESULT IN DEATH OR SERIOUS INJURY.

4 OPERATION

4.1 BEFORE OPERATING THE HOIST



WARNING:

ONLY TRAINED PERSONNEL SHALL OPERATE THIS EQUIPMENT. A TRAINED PERSON IS ONE WHO HAS READ AND THOROUGHLY UNDERSTANDS THIS INSTRUCTION MANUAL AND RELATED EQUIPMENT MANUALS AND, THROUGH TRAINING AND EXPERIENCE, HAS SHOWN KNOWLEDGE REGARDING THE SAFE OPERATIONAL PROCEDURES.



WARNING:

FOLLOW THE PRE-HOISTING CHECKLIST IN THE FRONT OF THIS MANUAL BEFORE OPERATING.

1. Read the safety labels provided with your hoist. These labels warn you of potential hazards that can cause serious injury. If a label comes off or becomes hard to read, contact Reimann & Georger Corporation for a free replacement.



WARNING:

THE HOISTING OPERATION MUST BE CLEAR OF ALL ELECTRICAL LINES AND OBSTRUCTIONS. CONSULT POWER COMPANY BEFORE WORKING NEAR POWER LINES.

2. Hoisting area is to be kept clear of unauthorized personnel. Place barricades or secure the area in such a manner that no personnel would be injured by the use of the equipment or by equipment failure.



WARNING:

PERSONEL MUST NEVER SECURE A LIFELINE TO THE HOIST FRAME STRUCTURE.

3. Ensure that all hoisting accessories such as slings are commercially manufactured, are in good condition, and have a rated load capacity of at least 300 lbs. When using a sling, note that its capacity decreases as the angle increases.

4.2 RAISING AND LOWERING THE LOAD



WARNING:

ENSURE 600 LBS. OF REIMANN & GEORGER CORPORATION APPROVED BALLAST BLOCKS ARE SECURED PROPERLY IN THE BALLAST BOX WITH ROPE BEFORE OPERATING THE HOIST. INADEQUATE COUNTERWEIGHT CAN CAUSE TOPPLING OF EQUIPMENT, RESULTING IN DEATH OR SERIOUS PERSONAL INJURY.



WARNING:

NEVER USE HUMAN BEINGS AS COUNTERWEIGHT.



WARNING:

NEVER ATTACH HOISTING ROPE TO ANY POWERED DEVICE. MANUAL OPERATION ONLY.

1. If using the optional handwinch, turn winch handle clockwise to raise a load and counter-clockwise to lower a load.



WARNING:

NEVER ALLOW ANYBODY TO RIDE ON THE HOIST AS THE EQUIPMENT IS NOT DESIGNED FOR THE SAME AND CAN RESULT IN DEATH OR SERIOUS INJURY.

2. Make a few “dry runs” with ballast in place, but no load to become familiar with the operation, and to test hoisting clearance. Do NOT attempt to make any equipment adjustments during operation.



WARNING:

THE WINCH DRUM MUST ALWAYS HAVE AT LEAST THREE TURNS OF WIRE ROPE WHEN THE LOAD IS AT THE LOWEST POINT OF TRAVEL.

3. Before lifting, secure the load from shifting and ensure the safety latch on the hook is not supporting any load. Use tag lines to control the load when there is danger it may swing or drift out of control. Never hoist over an open doorway.



WARNING:

SECURE LOAD BEFORE LIFTING.

4. The boom lock lever must securely lock the boom in position when hoisting a load and lowering it onto the roof. The lever must always be fully engaged into one of the three notch positions provided on the front leg assembly.
5. When hoisting from the ground ensure all personnel stand clear of the raised load.



WARNING:

KEEP OUT FROM UNDER A RAISED LOAD.

6. When hoisting a load from the roof, ensure OSHA compliant fall protection is in place and footing is on a firm surface. For maximum control of the load, multiple people on the roof should pull the rope simultaneously.



WARNING:

OSHA COMPLIANT FALL PROTECTION MUST BE IN PLACE AT ALL TIMES WHEN WORKING ON A ROOF OR OTHER ELEVATED PLATFORM.

7. Release the boom lock handle and use the boom tether to swing the load over to the rooftop.
8. Slowly lower the load to the roof deck. Do not remove the rope from the load until all tension has been relieved in the rope.

4.3 HAND SIGNALS

Hand signals have an important advantage over voice commands in high noise environments. Using hand signals insures proper synchronization of actions between the roof operator and the ground personnel and can give immediate warning of a potentially unsafe condition. All persons must be familiar with hand signals. Use the hand signals as shown in Figures 4-1 through 4-5.



WARNING:

A GOOD LINE OF COMMUNICATION MUST BE MAINTAINED BETWEEN THE HOIST OPERATOR AND ALL PERSONNEL FOR SAFETY. ALL PERSONNEL SHOULD UNDERSTAND HAND SIGNALS.



With forearm vertical, forefinger pointing up, move hand in small horizontal circle.

Figure 4-1.
“Hoist” Signal

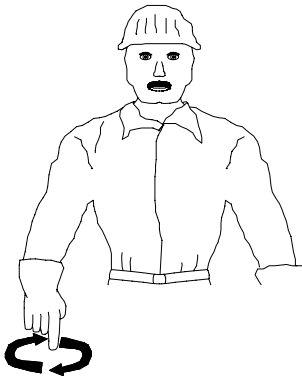

With arm extended downward, forefinger pointing down, move hand in small horizontal circle.

Figure 4-2.
“Lower” Signal

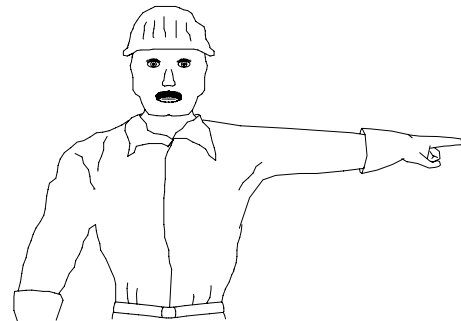

Arm extended, palm down, hold position rigidly

Figure 4-3.
“Stop” Signal

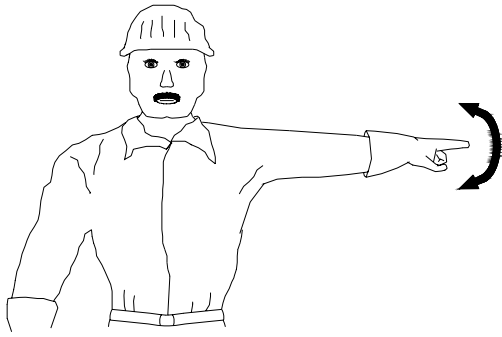

Arm extended, palm down,
move hand rapidly right and left.

Figure 4-4.
“Emergency Stop” Signal

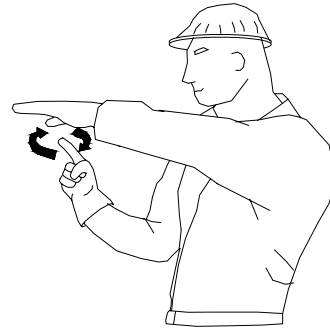

Use one hand to give any motion signal and place other hand
motionless in front of hand giving the motion signal.
(Hoist Slowly shown as example.)

Figure 4-5.
“Move Slowly” Signal

4.4 PREPARING HOIST FOR SHUTDOWN

At the end of operation, secure the equipment to prevent unauthorized use. **Never** assume you will find the equipment in the same condition that you left it. Proceed as follows:

1. Swing the boom to the 135° position over rooftop. Ensure that all lifting tension has been removed from the rope.
2. If the hoist is being permanently disassembled, at the end of a project for example, follow the detailed disassembly procedures in Chapter 5.

5 DISASSEMBLY



WARNING:

FOLLOW ALL THE SAFETY RULES DURING THE DISASSEMBLY OF THE HOIST. FAILURE TO DO THIS CAN LEAD TO DEATH, SERIOUS PERSONAL INJURY AND/OR EQUIPMENT DAMAGE.

5.1 REMOVING THE HOISTING ROPE

1. Lock the boom in the unloading position over rooftop.
2. Ensure that all lifting tension has been removed from the rope.



WARNING:

NEVER START DISASSEMBLING WITH THE HOIST SUPPORTING ANY LOAD.

3. Untie the rope securing the ballast blocks in the ballast box. Remove the ballast blocks and place them where they will not impede dismantling procedures.
4. Move hoist assembly away from roof edge.



WARNING:

NEVER DISASSEMBLE THE FRAME NEAR A ROOF EDGE. ANY ACCIDENT NEAR A ROOF EDGE CAN CAUSE DEATH OR SERIOUS PERSONAL INJURY.

5. Remove the shackle and safety hook. Remove the rope from the gin pulley. Then remove the gin pulley from the boom and the tag line from the boom D-ring.

5.2 DISASSEMBLING THE FRAME

1. If installed, remove the two (2) bolts and nuts from the optional operator fence.
2. Remove the wing screw holding the boom lock lever. Then remove the pin spring in the top of the front leg and remove the boom from the hoist.
3. Loosen the two wing screws on the front leg socket. Remove the counterweight upper mounting hardware and then separate the counterweight leg from the front leg.
4. Remove parts from roof deck.

6 INSPECTION AND MAINTENANCE

6.1 GENERAL MAINTENANCE RULES

1. Proper maintenance of the hoist and related equipment consists of adhering to all the guidelines given in this chapter and in the Pre-Hoisting Checklist in the front of this manual. Proper maintenance is required to maintain the system in good condition, which is defined as each part being free of rust or other corrosion, bends, breaks, or other defects.
2. Review and follow all the safety rules given in Chapter 1 before attempting any maintenance.
3. Only authorized personnel should be allowed in the maintenance area. Authorized personnel are the trained people as defined below and their supervision. Secure the area in such a manner that no personnel would be injured during the maintenance procedures or by equipment failure.
4. Repairs must be made only by trained personnel. A trained person is one who has read and thoroughly understands this instruction manual and related equipment manuals and, through training and experience, has shown knowledge regarding the safe operational procedures.
5. All authorized maintenance personnel must wear appropriate personal protective equipment, as a minimum, hard hat, safety glasses, and safety shoes.



WARNING:
WEAR HEAVY LEATHER GLOVES WHEN HANDLING THE HOISTING ROPE.

6. Do not weld or otherwise modify the hoist. Such alterations may weaken the structural integrity of the hoist and invalidate your warranty.



WARNING:
DURING ANY ERECTION, MAINTENANCE, OR REPAIR PROCEDURES, DO NOT ATTEMPT ANY HOISTING.

6.2 INITIAL INSPECTION

Hoist Frame assembly and dismantling must only be done by trained personnel as defined in Section 6.1. Each time after setting up the hoist and before placing it in service, all parts of the structure, boom, and other equipment must be thoroughly inspected by trained personnel as described in the remainder of this chapter.

6.3 DAILY INSPECTION

It is important that all the maintenance procedures outlined in the Pre-Hoisting Checklist in the front of this manual be done daily.

Inspect the hoisting rope prior to each use and at least daily for signs of wear and damage. Inspect the entire hoisting rope working length. While inspecting, examine any surfaces contacting the hoisting rope during operation. Correct any condition harming the rope in use or other damage or worn surfaces at this time.

All broken, worn or defective parts must be repaired or replaced before startup.

7 TROUBLESHOOTING

The following chart is intended to assist with troubleshooting the SH300 hand swing hoist. While not all inclusive, the chart outlines the most common causes of a problem and the recommended course of action.

SYMPTOM	CAUSE AND CORRECTIVE ACTION
Boom will not lock into unloading position over roof deck.	Stabilizer bar installed on wrong side of frame—stabilizer must be installed on the side opposite to where the boom is swung to handle loads on the roof deck.
Lifting the load is difficult or impossible.	Load not moving freely—ensure gin pulley rotates freely. Operator attempting to lift too much— reduce load weight as needed. Wire rope wound counter-clockwise on winch drum—feed wire rope over the top of drum and turn handle clockwise.

8 PARTS LIST

8.1 SH300 HOIST

Each item number on this parts list for the hoist assembly can be matched with the item number shown on the Figure 8-1 and 8-2 assembly drawings.

Item Number	Part Number	Quantity	Description
1	0204496	1	FRONT LEG ASSEMBLY
2	0204497	1	BOOM ASSEMBLY
3	0204498	1	COUNTERWEIGHT LEG ASSEMBLY
4	0204499	1	BALLAST BOX
5	0204494	1	STABILIZER BAR
6	0204469	1	COUNTERWEIGHT LEG SOCKET
7	5000214	2	SCREWLOCK
8	5800142	1	SPRING PIN
9	0200496	2	LEG BEARING
10	5806286	4	1/2" X 2-1/2" HEX HEAD CAP SCREW
11	5806379	5	1/2" HEX NUT
12	5806288	1	1/2" X 3" HEX HEAD CAP SCREW
13	6400654	1	RED GRIP
14	0204500	1	BOOM LOCK & LOCK LEVER ASSEMBLY
15	7306036	10 FT	MANILA ROPE
16	0132000	12	BALLAST WEIGHT
17**	0200563	1	GIN PULLEY
18*	0200086	1	OPERATOR FENCE KIT

* Optional part sold separately

** Part sold separately

8.2 SH300 HOIST W/ HANDWINCH

Each item number on this parts list for the hoist assembly can be matched with the item number shown on the Figure 8-3 and 8-4 assembly drawings.

Item Number	Part Number	Quantity	Description
1	0204496	1	FRONT LEG ASSEMBLY
2	0285315	1	HAND WINCH BOOM ASSEMBLY
3	0285310	1	HAND WINCH COUNTERWEIGHT LEG
4	0204499	1	BALLAST BOX
5	0204494	1	STABILIZER BAR
6	0204469	1	COUNTERWEIGHT LEG SOCKET
7	5000214	2	SCREWLOCK
8	5800142	2	SPRING PIN
9	0200496	2	LEG BEARING
10	5806286	3	1/2" X 2-1/2" HEX HEAD CAP SCREW
11	5806379	7	1/2" HEX NUT
12	5806288	1	1/2" X 3" HEX HEAD CAP SCREW
13	6400654	1	RED GRIP
14	0204500	1	BOOM LOCK & LOCK LEVER ASSEMBLY
15	7306036	10 FT	MANILA ROPE
16	0132000	12	BALLAST WEIGHT
17	0285320	1	WIRE ROPE ASSEMBLY W/ HOOK
18*	0200086	1	OPERATOR FENCE KIT
19	5806290	1	1/2" X 3-1/2" HEX HEAD CAP SCREW
20	5806281	2	1/2" X 1-1/4" HEX HEAD CAP SCREW
21	0285305	1	PIVOT SHEAVE ASSY
22	7300148	1	5/16" BOLT TYPE SHACKLE
23	0285405	1	PIVOT SHEAVE SUPPORT BRACKET
24	7702856	1	HANDWINCH
25	5806247	2	3/8" X 1" HEX HEAD CAP SCREW
26	5806377	2	3/8" HEX NUT
27	0285505	1	DIAGONAL BOOM BRACE
28	5000057	1	CABLE WEIGHT

* Optional part sold separately

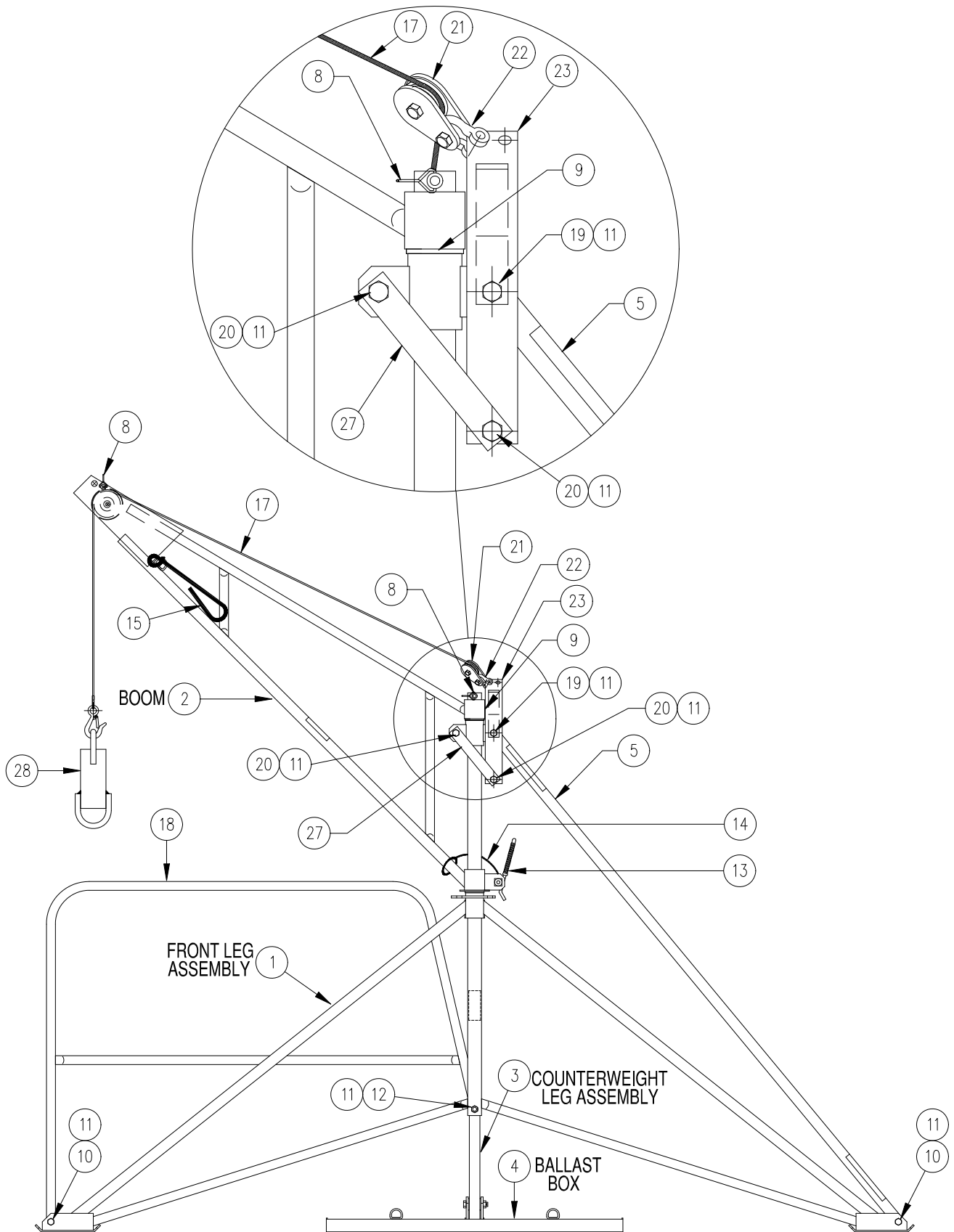

Figure 8-3
SH300 w/ Handwinch Assembly—Front View

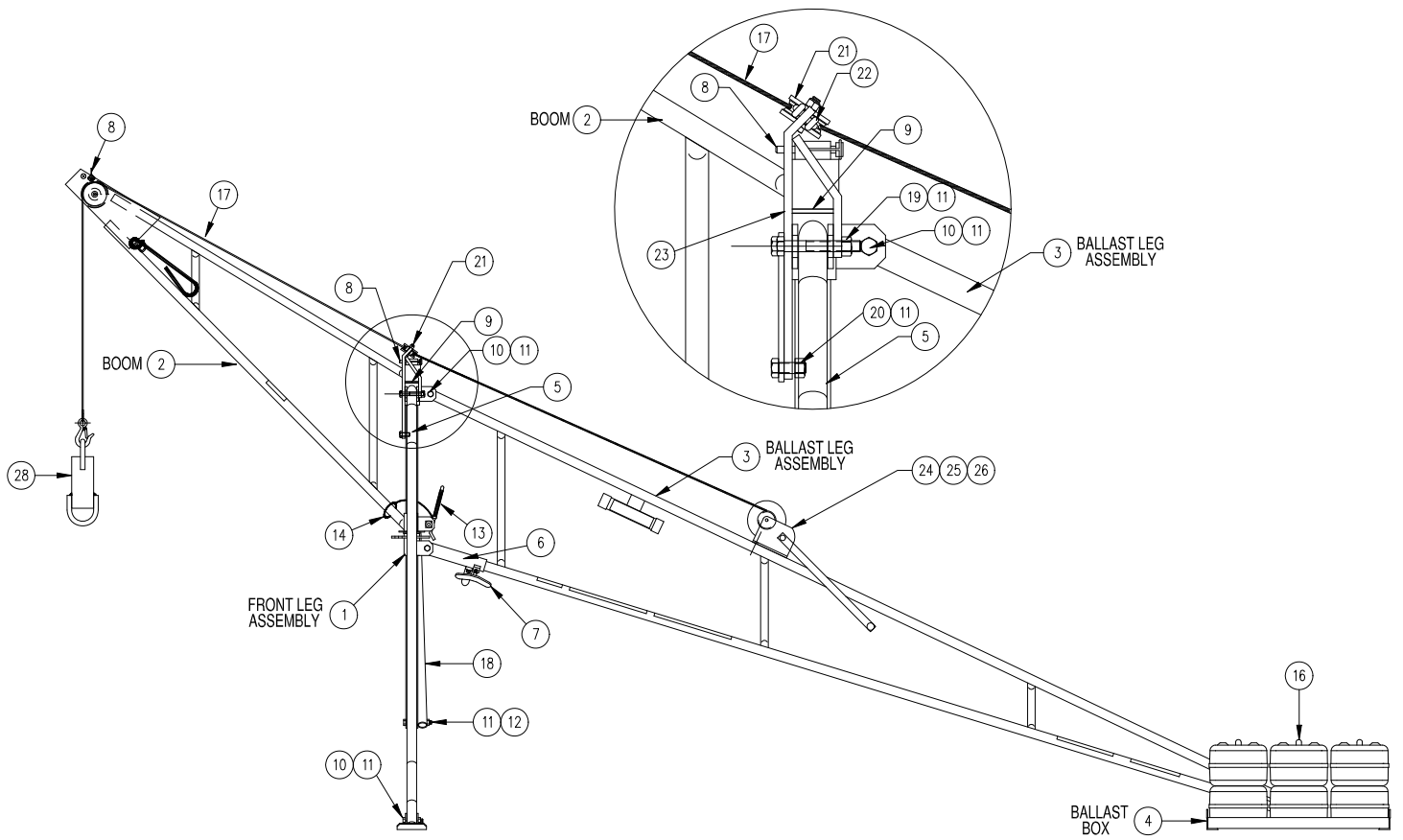

Figure 8-4
SH300 w/ Handwinch Assembly—Side View

LIMITED PRODUCT WARRANTY

**Reimann & Georger Corporation
Hoisting and Construction Products**

A. LIMITED WARRANTY

Reimann & Georger Corporation (the "Manufacturer") warrants to the original purchaser (the "Buyer") that all Reimann & Georger Hoisting and Construction products shall be free of defects in material and workmanship for a period of one (1) year from date of original purchase.

B. MANUFACTURER'S OBLIGATIONS

The Manufacturer's sole obligation under this Limited Warranty is the repair or, at the Manufacturer's discretion, the replacement of parts found to be defective. Parts and equipment must have authorization from the Manufacturer prior to return to the Manufacturer or repair by an authorized service person. Costs of transportation and other expenses connected with replacing or repairing parts are not covered under this Limited Warranty.

C. PARTS MANUFACTURED BY OTHERS

This Limited Warranty does not cover any parts manufactured by others. Such parts are subject to the warranty, if any, of their respective manufacturers, and are to be repaired only by a respective authorized service person for such parts. The Manufacturer shall have no obligation to undertake repairs of parts manufactured by others.

D. NO SPECIAL, INCIDENTAL, OR CONSEQUENTIAL DAMAGES

IN NO EVENT SHALL THE MANUFACTURER BE LIABLE TO THE BUYER OR ANY OTHER PERSON FOR ANY INDIRECT, SPECIAL, INCIDENTAL OR CONSEQUENTIAL LOSSES OR DAMAGES CONNECTED WITH THE USE OF THE PRODUCT UNDER THIS LIMITED WARRANTY. SUCH DAMAGES FOR WHICH THE MANUFACTURER SHALL NOT BE RESPONSIBLE INCLUDE, BUT ARE NOT LIMITED TO, LOST TIME AND CONVENIENCE, LOSS OF USE OF THE PRODUCT, THE COST OF A PRODUCT RENTAL, COSTS OF GASOLINE, TELEPHONE, TRAVEL, OR LODGING, THE LOSS OF PERSONAL OR COMMERCIAL PROPERTY, AND THE LOSS OF REVENUE.

E. NO LIABILITY IN EXCESS OF PURCHASE PRICE

IN NO EVENT SHALL THE MANUFACTURER'S OBLIGATIONS UNDER THIS LIMITED WARRANTY EXCEED THE PURCHASE PRICE OF THE PRODUCT.

F. NO EXTENSION OF STATUTE OF LIMITATIONS

ANY REPAIRS PERFORMED UNDER THIS WARRANTY SHALL NOT IN ANY WAY EXTEND THE STATUTES OF LIMITATIONS FOR CLAIMS UNDER THIS LIMITED WARRANTY.

G. WAIVER OF OTHER WARRANTIES

THE EXPRESS WARRANTIES SET FORTH IN THIS LIMITED WARRANTY ARE IN LIEU OF AND EXCLUDE ANY AND ALL OTHER WARRANTIES, EXPRESS OR IMPLIED, INCLUDING, BUT NOT LIMITED TO, THE IMPLIED WARRANTIES OR MERCHANTABILITY AND FITNESS FOR A PARTICULAR PURPOSE.

H. PROCEDURE FOR WARRANTY PERFORMANCE

If the product fails to perform to the Manufacturer's specifications, the Buyer must provide the Manufacturer with the applicable model and serial numbers, the date of purchase, and the nature of the problem.

I. ADDITIONAL EXCLUSIONS FROM THIS LIMITED WARRANTY. THIS LIMITED WARRANTY DOES NOT COVER ANY OF THE FOLLOWING:

1. Equipment which has been abused, damaged, used beyond rated capacity, or repaired by persons other than authorized service personnel.
2. Damage caused by acts of God which include, but are not limited to, hailstorms, windstorms, tornadoes, sandstorms, lightning, floods, and earthquakes.
3. Damage under conditions caused by fire or accident, by abuse or by negligence of the user or any other person other than the Manufacturer, by improper installation, by misuse, by incorrect operation, by "normal wear and tear", by improper adjustment or alteration, by alterations not completed by authorized service personnel, or by failure of product parts from such alterations.
4. Costs of repairing damage caused by poor or improper maintenance, costs of normally scheduled maintenance, or the cost of replacing any parts unless done as the result of an authorized repair covered by the one (1) year Limited Warranty.
5. Costs of modifying the product in any way once delivered to the Buyer, even if such modifications were added as a production change on other products made after the Buyer's product was built.

J. NO AUTHORITY TO ALTER THIS LIMITED WARRANTY

No agent, representative, or distributor of the Manufacturer has any authority to alter the terms of this Limited Warranty in any way.